



S-PBM360

ABOUT **PRAKASH**

Welcome to Prakash Group of Industries where you can see and Judge yourself about the latest development in paper bag technology and quality of the machine. We feel pleasure to introduce ourselves as one the leading manufacturers of paper bag machines in various cut off and sizes in India. You will not only find the broadest product range offered by any one manufacture but also numerous technical highlights which open up new dimensions in the industry. The company is well capable to meet the growing demand of Paper Bag Industry.

Prakash established a ultra modern HI-Tech manufacturing plant and all the components (i.e. Main frames, Shafts, Rubber rollers, Cylinders, Bushes etc.) are built in its own factory by a highly skilled team of engineers using most up to date manufacturing method guaranteeing consistent quality and finish. All of our paper bag machines are built entirely in our In-house state of the art production facilities. From Boring to cylinder grinding our large Investment allows us to produce parts that meet the exacting standard required to build a precision paper bag machines. Our promise to you, the customer, is simple "Nothing runs like our Machines".



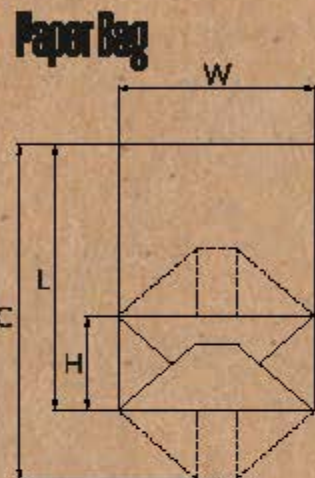

Advantages

Easy to use and operator friendly machine, helps in giving high production and maintenance free.

Fully automatic with plc control gives full control over the machine.

Small footprint enables easy installation and less space requirement.

Automatic lubrication system, increases machine life considerably.

Pneumatic reel lifting helps in quick changeover and less labor.

Auto tension control system keeps bag quality and finishing as per the International standards.

Automatic counting system helps in easy collection of finished paper bags and simpler production planning.

Options

Paper rope making.

Single or multicolour Flexographic printing units.

Paper handle making attachment.

Introduction

Square bottom paper bag making machine has got lot of applications. It can be used to produce shopping bags, grocery bags, food bags, paper bags with handles and stylish bags used for gifts.

This special machine produces the paper bag in one process from printed or unprinted roll paper, side gluing, roll folding, roll paper cutting, bottom folding, bottom gluing forming, bag formation in one go. Machine is controlled by PC programmable servo motor through the human-machine touch screen Interface. It can produce variety of specifications' paper bags. It has various advantages such as high production, quick changeover, operator friendly and fully automatic.

TYPE	S-PBM 360	S-PBM 450
Bag Width (W)	170-360MM	260-450 MM
Bottom Size (H)	85-180 MM	85-180 mm
Bag Tube Length (C)	270-530 MM	270-530 MM
Bag Length (L)	$L = C - (H+2+15-25)$	$L = C - (H+2+15-25)$
Max. Speed	220 Pcs/Min	180 Pcs/Min
Paper Thickness	60-170 GSM	80-180 GSM
Paper Roll Width	535-1110 MM	700-1250 MM
Max. Roll Diameter	1200 MM	1200 MM
Reel Inner Diameter	76 MM	76 MM
Total Power	11 KW	11 KW
Weight of Machine	5500 KG	6200 KG
Overall Dimension (L x W x H)	8500 x 1800 x 1900 MM	8500 x 2100 x 1900 MM

SPBM360

Roll Feeding Square Bottom Paper Bag Making Machine

Note - Machine speeds dependent on paper & adhesive qualities, bag dimensions, operator knowledge, and general work philosophy.

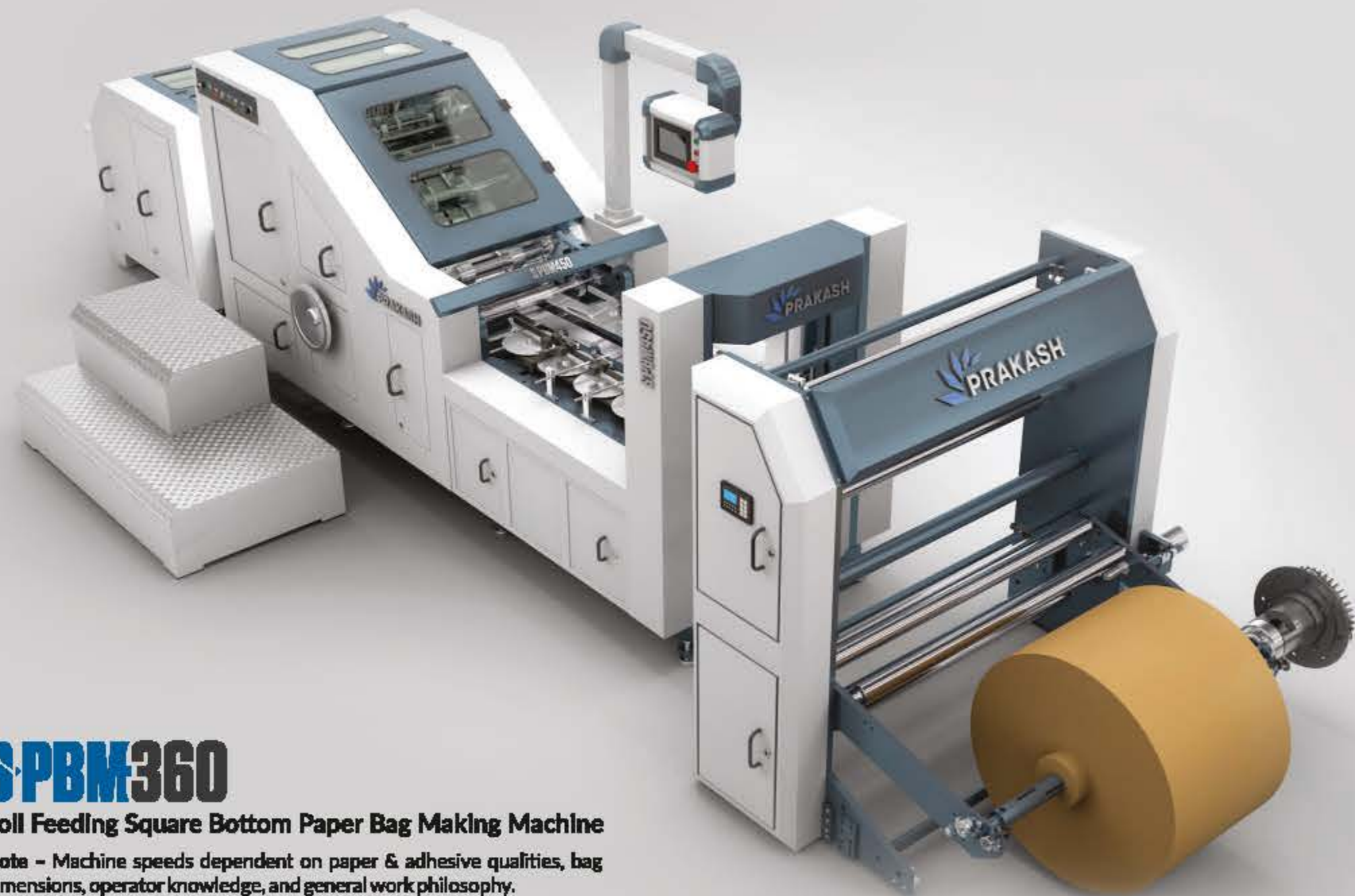

COLOR MARK TRACKING SYSTEM

Precise cut to print is achieved by highly accurate print mark sensor. Machine software easily reads print mark on the paper and cuts the paper bag length as per the mark. This feature helps in maintaining paper bag sizes and repeatability. In printed bags, this feature is quite useful as the printing does not shift during productions.



SIMPLISTIC TUBE FORMING SYSTEM

Prakash paper bag machine comes with simple system to adjust tube formation. This greatly helps in varying paper bag sizes and operator friendliness. Tube forming can be adjusted on the go and is fool proof to maintain high production.



AUTOMATIC COUNTING SYSTEM

The machine has automatic counting system. Not only it counts the total bags produced but operator can preset small batch size. As soon as small batch size is reached, one bag is slightly kicked out of the stack, making it quite easy to recognize and collect.



FULLY AUTOMATIC GLUE SUPPLY SYSTEM

Automatic glue supply system is adopted for coating at the bottom. If the amount of glue in the glue tank is insufficient, the glue will be supplied automatically to avoid glue solidification after the machine stops.



SMALL FOOTPRINT AND COMPACT DESIGN

The compact design of the machine, ensures that the paper travels smoothly. This helps in producing better quality paper bags and with better finishing.



TOUCHSCREEN AND PLC

Prakash machine uses highly adaptive touch screen and PC control system. This user friendly GUI shows real time data to the operator, enhancing ease of work. Highly precise

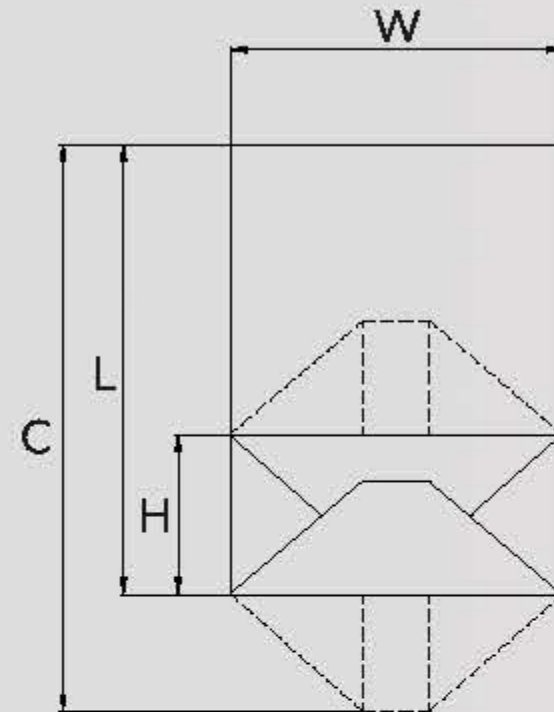

TWISTED PAPER ROPE MAKING MACHINE

TRM-500

Prakash TRM-500 is designed to make twisted paper rope. Twisted paper ropes are widely used to make handles for shopping bags. Rope made from the machine can be of different diameters as per the requirement. It's a high speed and high production twisted paper rope manufacturing machine. Fully automatic and require less manpower to operate. Paper roll of desired width is put at one end and at the other end re-winded twisted rope is made.

Technical Parameter

Model	TRM-500
Raw paper width	30-100mm
Rope diameter	2-4mm
Speed	10-30m/min
Diameter of coiled rope	400 x 400mm
The roll width	10-12mm
Width of paper roll	90-100mm
Power Consumption	500kg
Machine Weight	1000*1000*1300MM
Machine Dimensions	2200*1200*1100MM



Twisted Rope Handle Making Machine

RHM-1000

PRAKASH RHM-1000 twisted rope handle making machine is a high-speed paper handle making machine. It's fully automatic and operator friendly machine, wherein, twisted rope & paper are pasted together to form a handle. 2 rolls of paper and a bundle of twisted rope are fed into the paper handle making machine. Rope is pasted between 2 paper rolls and then cut at suitable length. Gluing and cutting are done within the machine and final twisted rope paper handles are delivered at the conveyor. Long conveyors are provided as an option.

Technical parameter

Model	TRM-500
Handle length	105-155mm
Handle width	95mm

Paper board width	35-55mm
Paper board length	114/152mm/190mm
Paper board weight	100-120g/m ²
Rope diameter	3-5mm
Speed	200-500
Total Power	6KW
Machine Weight	3 Ton
Machine Dimension	6000*1300*1800mm



Paper Rope Rewinding Machine

RR-700

Prakash Paper rope rewinding machine or rope rewinder is a robust machine which is used to rewind twisted paper rope rolls into bigger rolls. Smaller twisted paper rolls are rewinded using this machine, spliced with other rolls and then again rewinded on to a bigger rope roll. There is a great advantage in rewinding to a bigger twisted rope roll as with the bigger roll, there will be fewer stoppages of either automatic paper bag making machine or automatic paper rope handle machine where twisted ropes are used continuously.

Technical Parameter

Model	RR-700
Receives the volume diameter most greatly	600mm
Paper volume altitude	500mm
Paper cord diameter	3-4mm
Voltage	380V
Machine Weight	0.5T
Power	2.2Kw
Speed	200meters/Mins
Machine Size	1000*1000*1300MM





PRAKASH WEB OFFSET PVT. LTD.

Plot no. 268,269,270 Sector 58, Faridabad 121004 Haryana, India.
info@prakashoffset.com | www.prakashoffset.com
24X7 Help Line - +91 82875 55666 | 95997 55114